

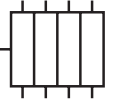

## Progressive distributor in element construction VPI-D



### Use:

In progressive mode based central lubrication systems.

### The main features of WOERNER progressive distributors are as follows:

- **4 different proportioning volumes** that are selectable according to the lubricant volumes required
- **Accurate proportioning volumes**
- **Extremely long service life** due to refined sliding surfaces
- **Modular system construction**
- **No proportioning decrease at the piston monitored**

### Particularities of progressive distributors in element construction:

- Individual proportioning elements as well as dummy elements may **subsequently be replaced** or built-in.<sup>1)</sup> (Alteration of proportioning volumes or functional controls.)
- **Proportioning volumes** can be allocated to the outlets during assembly.
- **Clogged lines to lubrication points** can be **localised** without requiring screwed joints to be loosened.

### Technical data:

Proportioning volume per cycle: 0,9 ... 3,7 cm<sup>3</sup>  
 Lubrication point connections at max.: 20  
 Operating pressure at max.: 150 bar  
 Throughput volume<sup>2)</sup> in case of  
 Oil at max.: 6000 cm<sup>3</sup>/min  
 Grease at max.: 600 cm<sup>3</sup>/min  
 Delivery medium:  
 Oil-viscosity: 6 cP  
 Grease: up to NLGI category 2  
 Temperature range: -20 ... +80 °C  
 Material:

Connecting plate: Aluminium  
 Proportioning elements: Steel (surface treated)

Gasket: FPM (Viton)  
 Fitting position: usually as needed

Note: In case of heavy vibration or shock load, install the distributor such that piston axes are situated vertically to the main direction of shock impact.

<sup>1)</sup> Note: Due to proportioning volume alteration, the allocation volume to all outlets as well as the cycle time may change.

<sup>2)</sup> The maximum throughput volume depends on viscosity or penetration of the number of points and proportioning sizes.

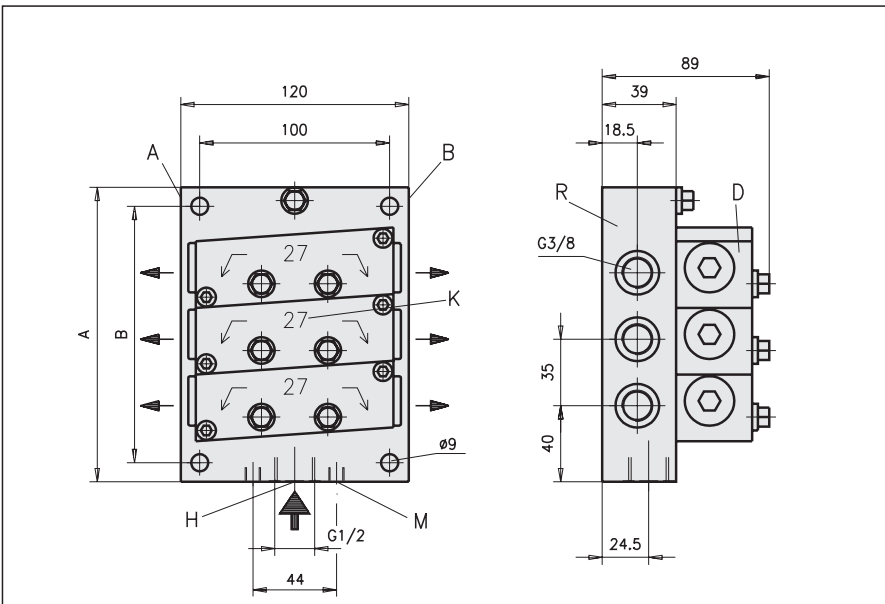
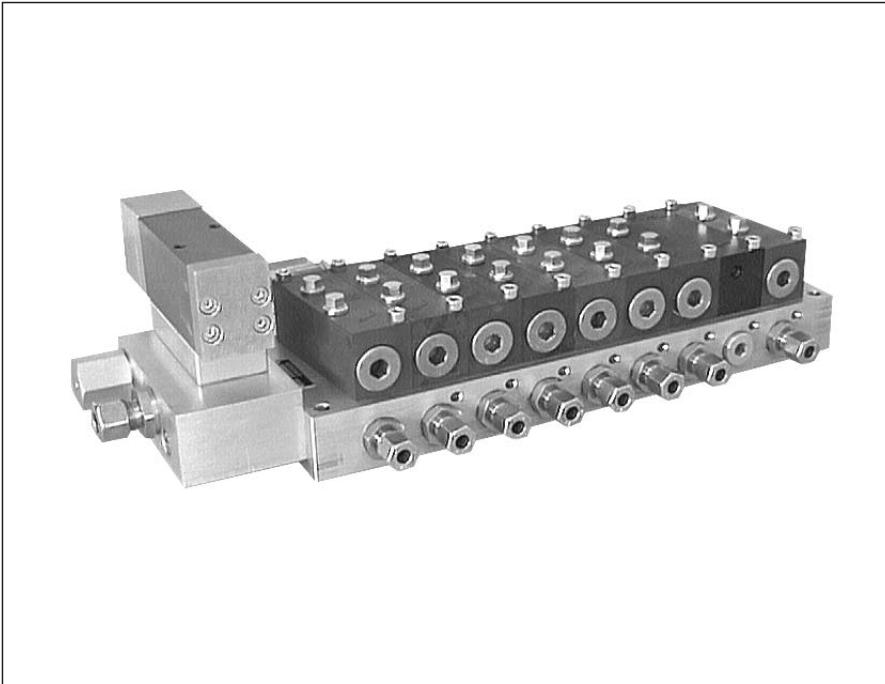

- A = Assembly side "A" for functional check.
- B = Assembly side "B" for functional check.
- D = Proportioning element DPI-D
- H = Input line
- K = Proportioning volume distinctive number
- M = 2 M8 fastening threads for assembly of auxiliary units
- R = Connecting plate API-D

Number of outlets	Length "A"	Length "B"	Weight [kg]
6	155	135	5,0
8	190	170	6,5
10	225	205	8,0
12	260	240	9,5
14	295	275	11,0
16	330	310	12,5
18	365	345	14,0
20	400	380	15,5

- Subject to modifications -

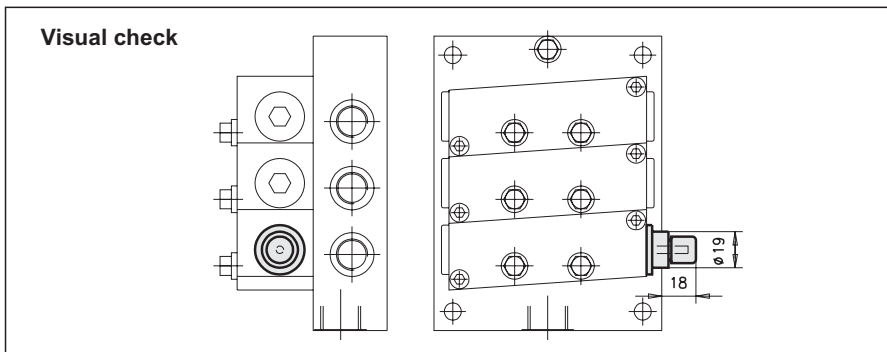

**Functional checks:**

**Visual check:**

In a translucent polyamide casing, a red pin being fixed to the piston shows the piston's movement.

Casing material: Polyamide, translucent  
 Ambient temperature: -10 ... +80 °C

**Electrical check with initiator:**

**Casing for initiator:**

A pin being connected with the piston attenuates an initiator once per cycle.

Version "D":  
 Casing material: Polyamide, translucent  
 (Piston movement is visible)  
 for initiators with a switching distance of:  $\geq 8$  mm

Version "W":  
 Casing material: Polyamide, black  
 for initiators with a switching distance of:  $\geq 5$  mm

Use initiator with M18x1 thread!  
 (When using other initiators than those depicted below, such initiators must be checked for suitability.)

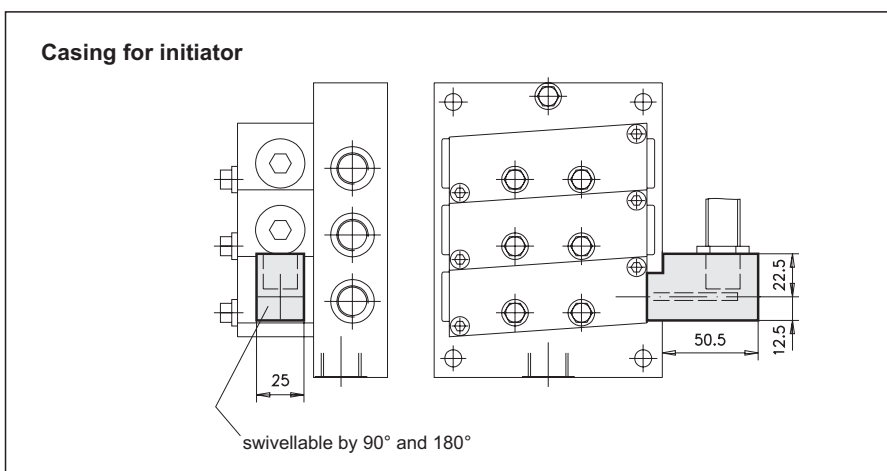

- Subject to modifications -

**Choice of initiators:**

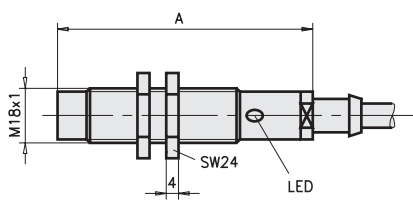
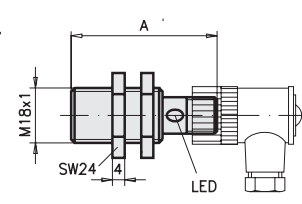
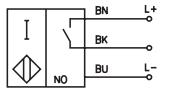
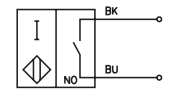
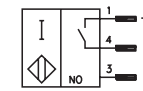
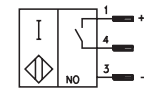
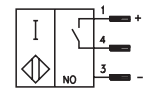
Designation / Purchase-no.	<b>Initiator "C"</b> 913.900-03	<b>Initiator "F"</b> 913.900-11	<b>Initiator "N"</b> 913.900-21	<b>Initiator "I"</b> 913.900-14	<b>Initiator "2"</b> 979.044-88
Suits for	Casing "W" Switching dis. $\geq 5$ mm	Casing "D" and "W" Switching dis. $\geq 8$ mm	Casing "D" and "W" Switching dis. $\geq 8$ mm	Casing "W" Switching dis. $\geq 5$ mm	Casing "W" Switching dis. $\geq 5$ mm
Dimension drawing:					
Connection diagram:					
Operating voltage:	10 ... 30 VDC	20 ... 250 VUC	10 ... 30 VDC	10 ... 30 VDC	10 ... 30 VDC
Residual ripple:	$\leq 10\%$		$\leq 15\%$	$\leq 15\%$	$\leq 15\%$
Load current at max.:	250 mA	500 mA	130 mA	200 mA	130 mA
Protection system:	IP67	IP67	IP67	IP67	IP67
Power connection:	Cable 2 m	Cable 3 m	Unit plug (see accessories page 3)		
Length "A":	60 mm	62 mm	45 mm	100 mm	65 mm



- Subject to modifications -

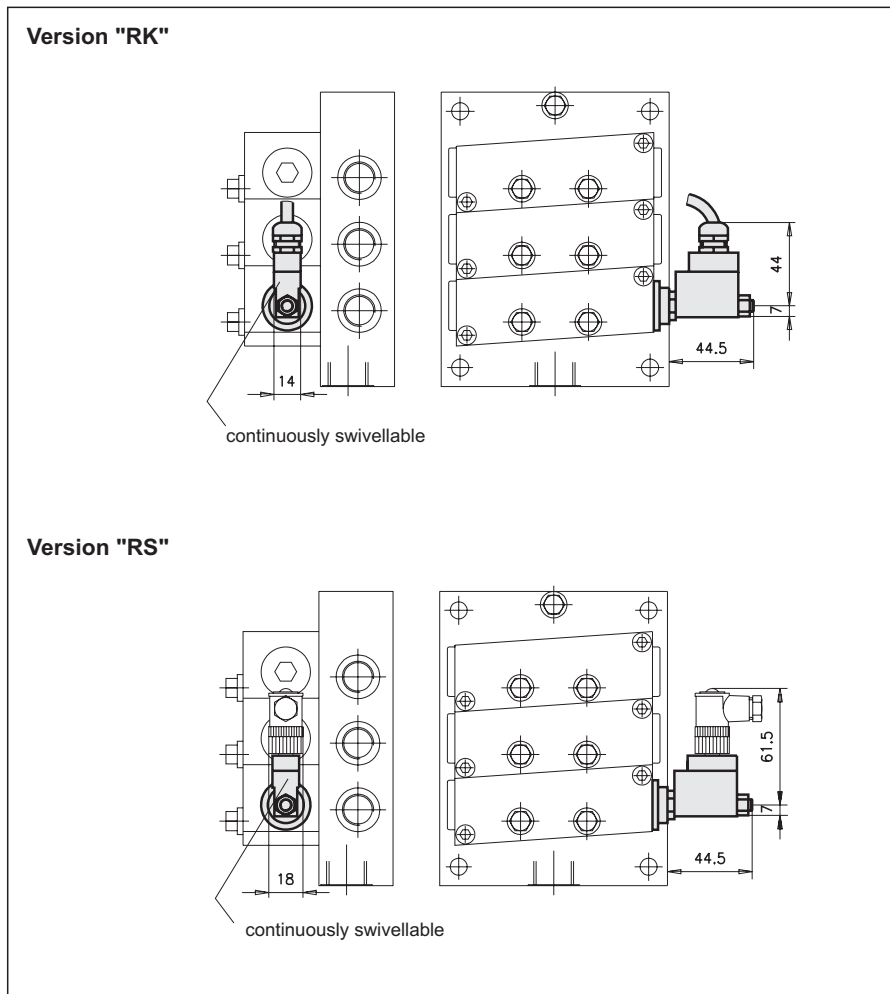

### Electrical check with reed contact:

A magnet connected with the piston switches the Reed contact once per cycle.

Switching voltage: 10 ... 36 VUC  
 Switching current at max.: 25 mA  
 Switching power at max.: 0,9 VA  
 Ambient temperature: -5 ... +80 °C

### Version "RK" with cable:

Material (casing): PA or 1.4305  
 System of protection: IP65  
 Cable  
 Length: 10 m  
 Cross section: 2x0,75 mm<sup>2</sup>  
 Material: Ölflex

Connection diagram: BN — 100 R — BU

### Version "RS" with unit plug, 4-pin (M12):

(For matching cable jack see accessories)

Material (casing): PA or 1.4305

Connection diagram: 1 — 100 R — 4

### Accessories:

Cable jack for functionality check "RS" and initiator (state purchase-no., please)

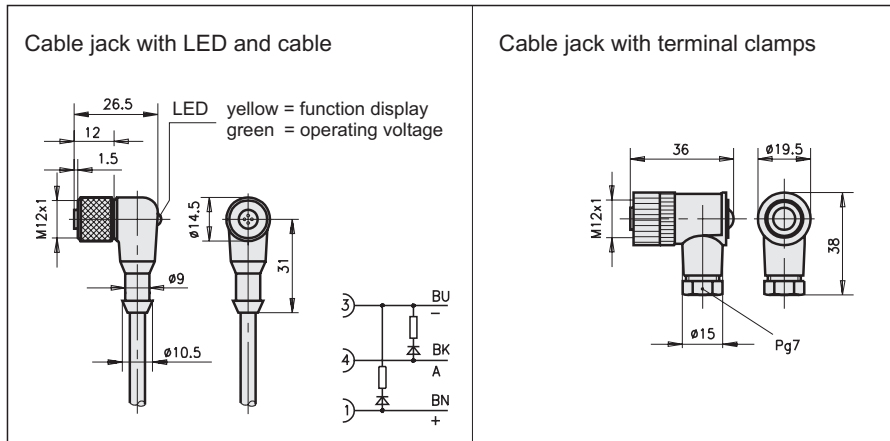

### Cable jack with LED and cable:

Purchase-no.: **913.404-19**  
 Operating voltage: 10 ... 30 VDC  
 Cable  
 Cross section: 3x0,34 mm<sup>2</sup>  
 Length: 5 m  
 System of protection: IP68

### Cable jack with terminal clamps: (without LED)

Purchase-no.: **913.404-24**  
 Connection type: Screws  
 Connection cross section at max.: 0,75mm<sup>2</sup>  
 Cable diameter: 4 ... 6 mm  
 System of protection: IP67

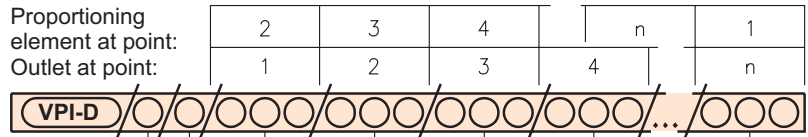
**Purchase-designation:**

**Progressive distributor**

Connecting plate		Proportioning element <sup>1)</sup>				
Number of outlets	Add-on element at inlet side	Proportioning volume per piston stroke and outlet [cm <sup>3</sup> ]		Functionality check <sup>2)</sup>		Assembly side
6 ... 20 increasing by 2 outlets each	ⓐ ..... ⓑ	0,9	ⓐ	Visual check	translucent initiator casing switching distance ≥ 8mm: with initiator "N" (DN) with initiator "F" (DF) without initiator (D0)	Side A (A)
	For direct mounting of power and directional control valves at the distributor inlet	1,8	ⓑ			
		For description see leaflet-no. 0684	2,7	ⓒ	without func- tionality check: n/a.	
	without ⓓ	3,7	ⓓ			
			Dummy	ⓔ		

**Connecting plate** 
**Proportioning element** 

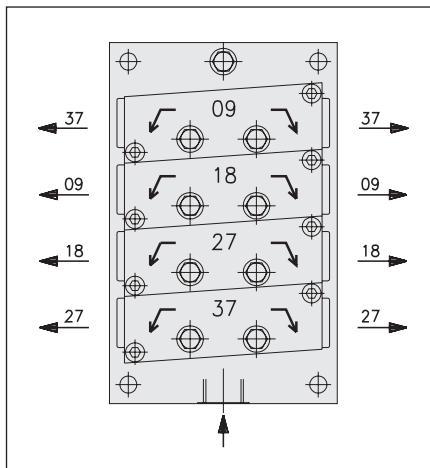
**Note:**  
 The order in which the proportioning distinctive numbers are stated does not correspond to the order in which the proportioning elements are mounted. The proportioning distinctive numbers are stated as they are assigned to the respective outlets.

**Example: VPI-D / 8 / 0 / 27 / 18 / 09 / 37**

The proportioning element having a proportioning volume of 2,7 cm<sup>3</sup> is, by means of its distinctive number "27" to be stated in the purchasing number first. It proportions to the outlets at point 1. It is, however, mounted at point 2.

The proportioning element having a proportioning volume of 1,8 cm<sup>3</sup> is, by means of its distinctive number "18" to be stated in the purchasing number second. It proportions to the outlets at point 2. It is, however, mounted at point 3.

The proportioning element having a proportioning volume of 3,7 cm<sup>3</sup> is, by means of its distinctive number "37" to be stated in the purchasing designation last. It proportions to the outlets at the last point. It is, however, mounted at point 1.

<sup>1)</sup> Three proportioning elements need to be selected at least.

- Subject to modifications -



Extended purchase designation: <sup>2)</sup>

- outlet pipings
- combinations
- check valves

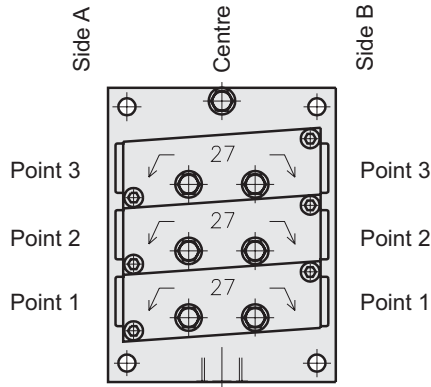

Proportioning element at point	2	3	4	n	1
Outlet at point	1	2	3	4	n
Side A	0	0	0	0	0
Centre	Z	Z	Z	Z	Z
Side B	0	0	0	0	0

Outlet screw fittings Bridges Check valves	Outlet		Bridge			Straight screw fittings for outer pipe diameters					Swivelling screw fitting f. outer pipe diameters	
	open	closed	without double	with outlet triple	with outlet	6	8	10	12	15		12
without check valve	0	V	B	P	A	1	2	3	4	5		7
with check valve	-	-	BR	PR	AR		2R	3R				

Screw "Z"	
(K)	without
(Z)	with

- Subject to modifications -

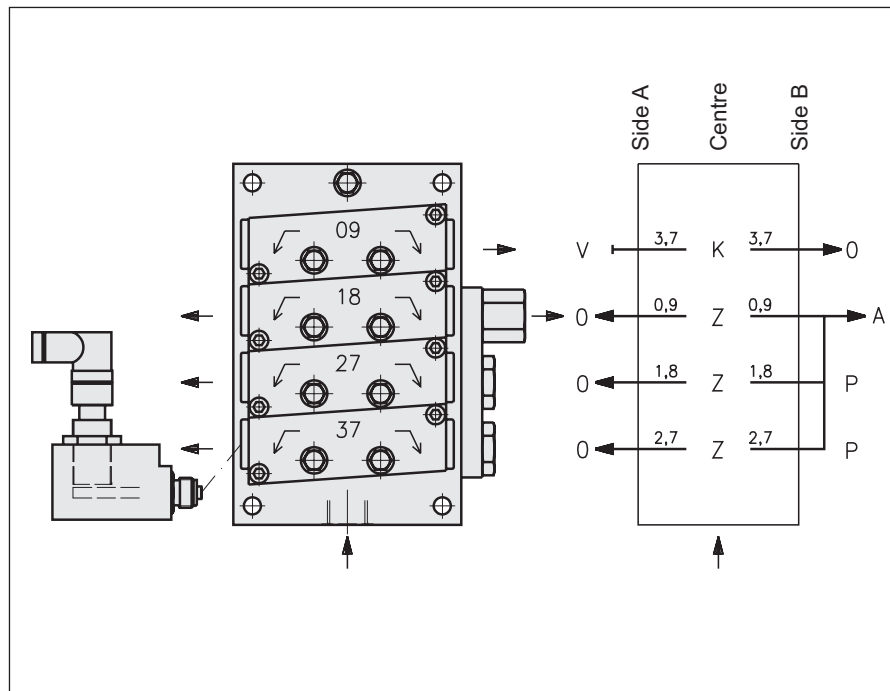

**Purchase-example**  
for the distributor as depicted here:

VPI-D progressive distributor with 8 outlets, without add-on element on inlet side, proportioning distinctive numbers "27", "18", "09", "37", with casing for initiator "W" and initiator "C" at proportioning element point 1, side "A".

**Purchase-designation:**  
(incl. outlet elements enumeration)

VPI-D / 8 / 0 / 27 / 18 / 09 / 37WCA  
Side A: 0 / 0 / 0 / V  
Centre: Z / Z / Z / K  
Side B: P / P / A / 0

<sup>2)</sup> When no data are given, the distributor will be equipped without outlet screw fitting elements and with "Z" screws.

**Add-on elements and combination of outlets:**

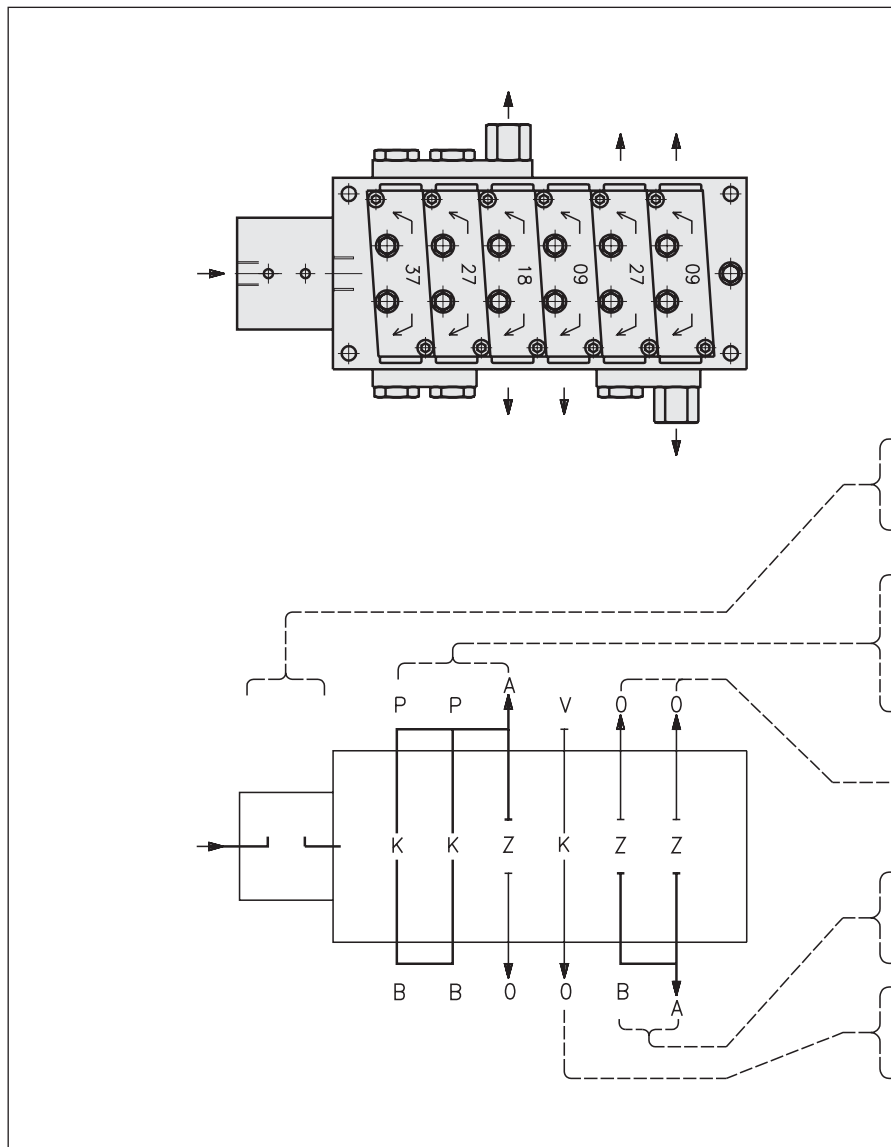

Distinctive letters:

- B = double bridge without check valve
- BR= double bridge with check valve
- P = triple bridge without check valve
- PR= triple bridge with check valve
- A = outlet at the bridge without check valve
- AR= outlet at the bridge with check valve
- Z = opposing outlets separated
- K = opposing outlets connected
- O = open outlet
- V = Lock screw
- C0; C1 etc. = Add-on elements at distributor inlet

Add-on element for mounting of auxiliary units such as directional control valves, flow control valves, etc.

5 outlets are combined into one outlet by means of a triple bridge, a double bridge, and removal of the "Z" screws.

Open outlets

2 adjacent outlets are combined into one outlet by means of a double bridge.

2 opposing outlets are combined by removing the "Z" screws.

- Subject to modifications -

**Blind element (proportioning volume "00"):**

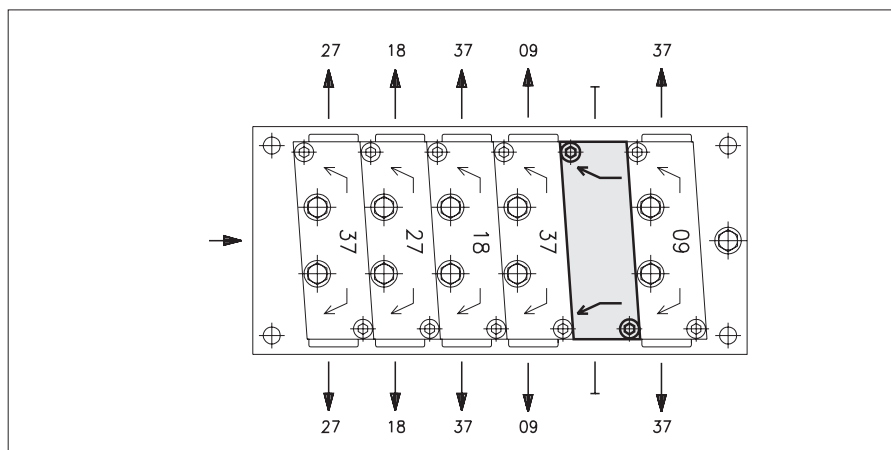

**Blind element:**

For subsequent modification of the number of lubrication points, blind elements can be mounted instead of proportioning elements. Below the blind elements, no volumes are ejected.

Please note:

- Any subsequent modification of the number of lubrication points will change both the proportioning volume to all outlets and cycle time.
- For function-technical reasons, 3 proportioning elements must be mounted at least.

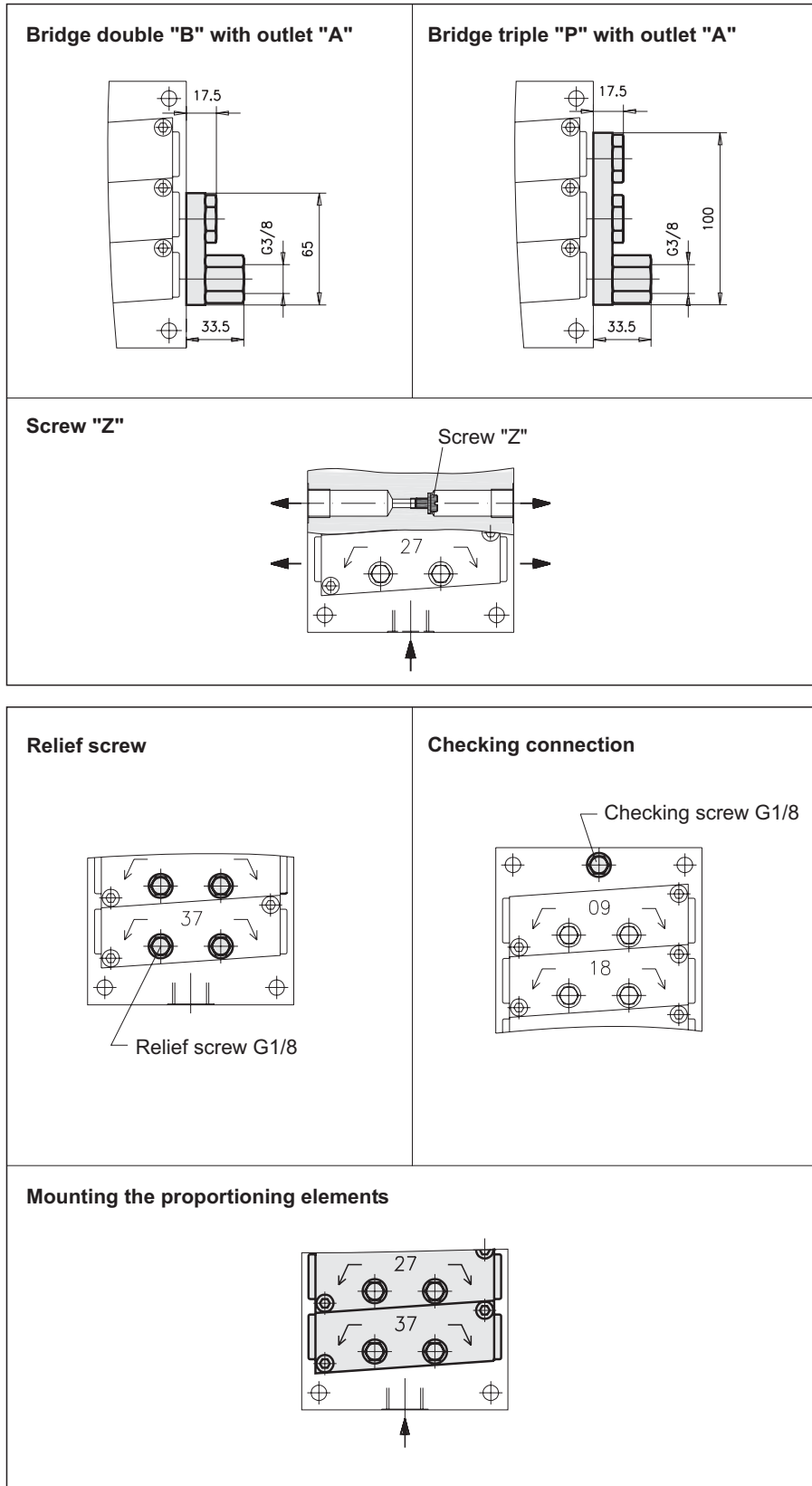

**Combining of outlets:**

**Bridges:**

Adjacent outlets can be combined by bridges as follows:

- as needed with or without outlet connection
- as needed with or without check valves

**Material:**  
Hollow screw: Steel galvanised  
Bridge body: Aluminium

**Screw "Z":**

Opposite outlets can be connected by removing the "Z" screw. When removing that screw, one outlet must be closed.

**Relief screw:**

The hole towards the relief screw is directly linked with the outlet situated beneath.

In case of fault, e.g. due to a clogged lubricant point line, the faulty spot can be localised by opening the relief screw.

**Test connection:**

The test connection is directly linked with the inlet line. Hence the inlet pressure can be shown or monitored at that point.

**Mounting the proportioning elements:**

Starting from the distributor inlet side, the proportioning elements are to be mounted downward into the arrow's direction.

**Venting the distributor:**

Prior to distributor start-up, it must be vented. To this effect, open the checking screw for the inlet line as well as the relief screws for the respective outlets.

- Subject to modifications -

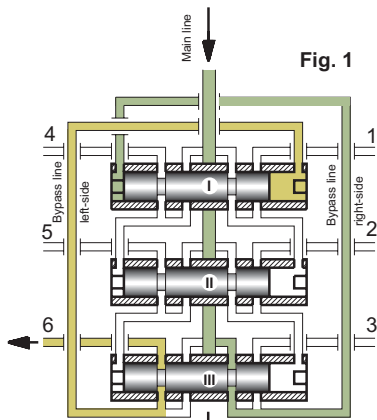

Fig. 1

**Functional process fig. 1 ... 4:**

The lubricant flows from the main line through the right-side ring groove of piston III as well as the bypass line (right) and to the left side of piston I and moves it into its home position. The lubricant displaced by piston I is ejected via the left bypass line through outlet no. 6.

**Monitoring of progressive distributors:**

As for instance due to soiling, the flow through a lubricant point line may be prevented. This will cause a piston to get blocked. By virtue of the forced control as depicted in figures 1 up to 4, the other pistons will be stopped as well. Due to this configuration, the proportioning at all outlets of the distributor can be monitored by means of a sensor at one piston only.

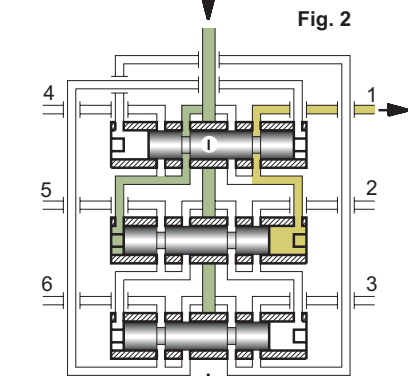

Fig. 2

After shifting of piston I, lubricant flows to the left side of piston II and pushes it into its right-side home position. The displaced lubricant is ejected via outlet no. 1.

**Mounting note:**

The pistons are provided with an extremely small fitting clearance. Therefore, the pistons, after the dismantling of a distributor, must never be interchanged.

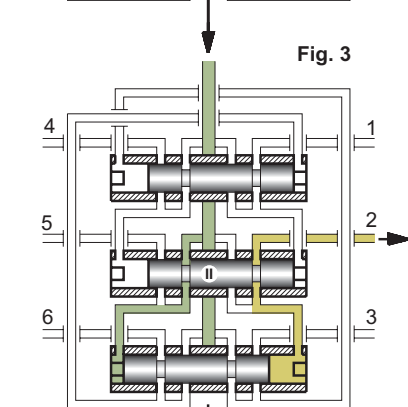

Fig. 3

After shifting of piston II, lubricant flows to the left side of piston III and pushes it into its right-side home position. The displaced lubricant is ejected via outlet no. 2.

**Formula for calculating the lubricant available per lubrication point:**

A progressive distributor allocates the delivered lubricant to the individual lubrication points in forced order. Due to the functional process as described herein, a safe proportioning is ensured.

The lubricant  $q_i$  delivered to a lubrication point  $i$  can be calculated as follows

$$q_i = \frac{K_i}{2 * (K_1 + K_2 + K_3 \dots)} * Q$$

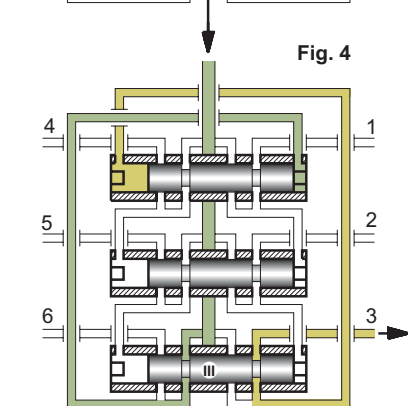

Fig. 4

After shifting of piston III, lubricant flows to the right side of piston I and pushes it into its left-side home position. The displaced lubricant is ejected via outlet no. 3. The continuation of that process is evidenced in the scheme depicted.

$Q$  = lubricant delivered to the distributor,  
 $K_i$  = distinctive number of the outlet  $i$

- Subject to modifications -